

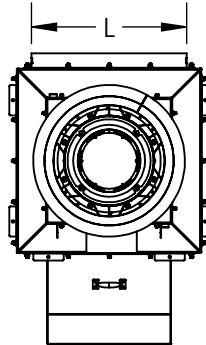

DATE: TAG:
 JOB:
 PROJECT:
 COMPANY:
 SALES PERSON:

IPLUME WITH 1X1 PLENUM
 DIRECT DRIVE, SIDE INLET



A = OVERALL SYSTEM HEIGHT (WITHOUT CURB)
 B = WIDTH OF PLENUM (INSIDE)
 D = OVERALL WIDTH OF THE SYSTEM
 E = HEIGHT OF PLENUM
 F = HEIGHT OF FAN
 G = DIA. OF NOZZLE
 H = DIA. OF WINDBAND COLLAR
 K = HEIGHT OF COMPANION FLANGE
 L = LENGTH OF COMPANION FLANGE

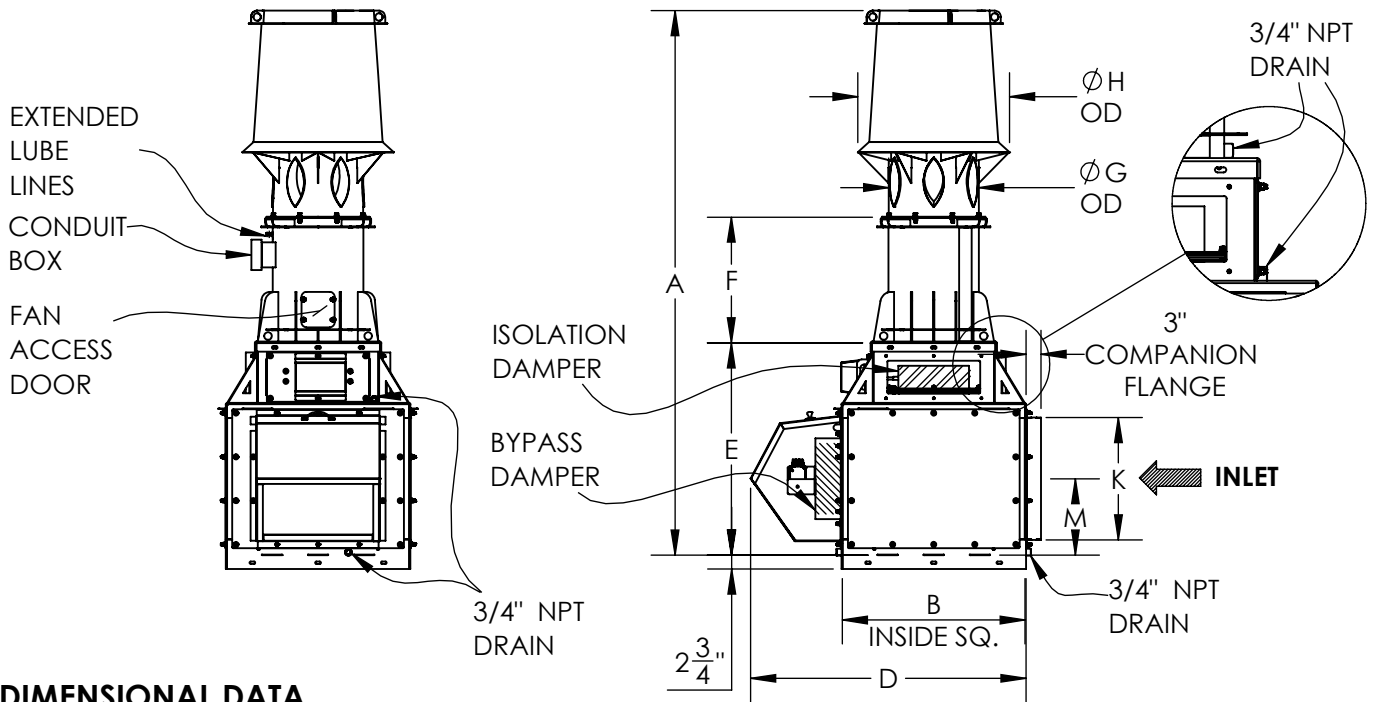

DIMENSIONAL DATA

Size	A	B	D	E	F	G	H	K	L	M	MAX MTR FRAME SIZE	LESS MOTOR/ DRIVE WEIGHT (LBS.)
122	107 3/4	36 5/16	54 1/2	42	24 7/8	17 7/8	30 1/16	24 3/16	30 11/16	15 1/8	145T	1025
135	114 3/4	39 5/16	57 1/2	42	27 9/16	19 3/4	33 1/8	24 3/16	33 11/16	15 1/8	145T	1130
150	122 11/16	45 5/16	63 1/2	42	30 5/8	21 15/16	36 13/16	24 3/16	39 11/16	15 1/8	145T	1302
165	123 5/8	46 5/16	64 1/2	42	33 11/16	23 7/16	40 5/8	24 3/16	40 11/16	15 1/8	184T	1387
182	138 7/16	53 5/16	73 5/8	48 1/16	37 3/16	25 13/16	44 15/16	30 3/16	47 11/16	18 1/8	215T	2041
200	146 13/16	57 5/16	77 5/8	48 1/16	40 15/16	28 3/8	49 3/16	30 3/16	51 11/16	18 1/8	256T	2215
222	157 15/16	61 5/16	81 5/8	48 1/16	45 7/16	31 7/16	54 3/4	30 3/16	55 11/16	18 1/8	286T	2508
245	155 15/16	62 5/16	82 5/8	50 3/4	50 3/16	34 11/16	53 9/16	30 3/16	56 11/16	18 1/8	286T	2629
270	163 15/16	65 5/16	85 5/8	48 1/16	55 5/16	38 3/16	59 1/16	30 3/16	59 11/16	18 1/8	326T	2801
300	182 7/8	71 5/16	93 3/4	54 1/16	61 1/2	42 7/16	65 9/16	36 3/16	65 11/16	21 1/8	326T	3318
330	196	78 1/4	100 3/4	54	67 3/4	46 5/8	72 1/8	36 3/16	72 11/16	21 1/8	365T	3770
365	193 1/2	81 1/4	103 13/16	60	74 15/16	51 5/8	67 3/8	42 3/16	75 11/16	24 1/8	404T	4406
402	206 15/16	86 1/4	108 13/16	60	82 9/16	56 3/4	74 5/16	42 3/16	80 11/16	24 1/8	405T	4945
445	246 15/16	92 1/4	123 1/4	84	91 7/16	62 3/4	82 1/8	66 3/16	86 11/16	36 1/8	445T	6098

ALL DIMENSIONS ARE IN INCHES

REVISION:

FORM:

REPLACES: